

Compact gantry wet cut-off machine – series FTN-200S

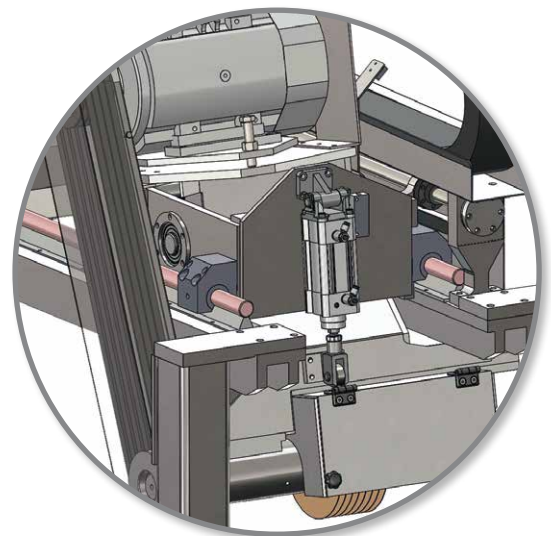

The **FTN-200S** gantry wet cut-off machine has been designed to cut panels and flat components made of carbon fibre and similar materials. It is suitable for the use of CBN diamond cutting discs.



Cutting device

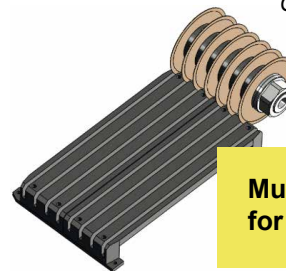

Multiple disc fixings allow for multiple cuts.

The machine is certified with the CE mark in accordance with EC Directive 2006/42/EC.

Characteristics:

- + **Intuitive and user-friendly controls**
- + **Stepless control of drive and axis during operation** for flexible, precise, and efficient processes
- + **Optimal cooling/rinsing performance** thanks to large water distribution
- + **Easy access** thanks to large sliding door
- + **Better visibility of the work area** thanks to side windows
- + **Coolant distribution system** for precise and material-saving work

Compact gantry wet cut-off machine – series FTN-200S**Technical details:**

Workpiece sizes	500 x 400 x 30 mm
Cutting disc sizes	200–300 mm
Stepless speed control	20–53 (30–63) m/sec
Travel distances	X-axis: 700 mm
Drive power	10 kW
Traversing axis	with servomotor and driven ball screw
Integrated clamping table	for complex cutting tasks
Large coolant distribution system	for precise and material-saving work
Central lubrication	easy to maintain and durable

Everything from a single source:

Thanks to our integration into the **Pütz Group** and the resulting **synergy effects** we are able to offer you not just production and specialist cutting-off machines but also the appropriate testing technology to test surfaces as well as for dimensional accuracy.

Sampas + Silvercut GmbH
Bahnhofstraße 8/1
74821 Mosbach
GERMANY

info@silvercut.de
Phone: +49 6261 9726-0
www.silvercut.de

